



CPD15/20/30/35L1

Electric Counterbalance Forklift

Truck 1.5/2.0/3.0/3.5T LI-ION TECHNOLOGY

- High efficiency with high performance
- Waterproof design suitable for various of weather
- Standard lithium battery, fast charging and convenient using
- High comfort for operation with larger cab

EP EQUIPMENT CO.,LTD
www.ep-ep.com



Electric Counterbalance Forklift Truck 1.5/2.0T

CPD15/20L1

Distinguishing mark					
1.1	Manufacturer			EP	EP
1.2	Model designation			CPD15L1	CPD20L1
1.3	Drive unit			Electrics	Electrics
1.4	Operator type			seated	seated
1.5	rated capacity	Q	t	1.5	2
1.6	Load center distance	c	mm	500	500
1.8	Load distance, centre of drive axle to fork	x	mm	405	405
1.9	Wheelbase	y	mm	1470	1470
Weight					
2.1	Service weight (include battery)		kg	2640	2950
2.2	Axle loading, laden driving wheels /steering wheels		kg	3615/525	4380/570
2.3	Axle loading, unladen driving wheels /steering wheels		kg	1190/1450	1155/1795
Types,Chassis					
3.1	Tyre type,driving wheels /steering wheels			solid rubber	solid rubber
3.2	Tyre size, driving wheels			18X7-8	18X7-8
3.3	Tyre size, steering wheels			5.00-8	5.00-8
3.5	Wheels, number driving/steering (x=drive wheels)		mm	2x/ 2	2x/ 2
3.6	Tread, Driving wheels	b ₁₀	mm	910	910
3.7	Tread, Steering wheels	b ₁₁	mm	920	920
Dimensions					
4.1	Tilt of mast/fork carriage forward/backward	α/ β (°)		6/ 11	6/ 11
4.2	Height, mast lowered	h ₁	mm	2080	2080
4.3	Free lift (load backrest)	h ₂	mm	105	105
4.4	Lift height	h ₃	mm	3000	3000
4.5	Height, mast extended	h ₄	mm	4028	4028
4.7	Height of overhead guard (cabin)	h ₆	mm	2080	2080
4.8	Seat height	h ₇	mm	1050	1050
4.12	Tow center of pin height	h ₁₀	mm	360	360
4.19	Overall length	l ₁	mm	3270	3270
4.20	Length to face of forks	l ₂	mm	2200	2200
4.21	Overall width	b _{1/} b ₂	mm	1080	1080
4.22	Fork dimensions	s/ e/ l	mm	40x100x1070	40x122x1070
4.23	Fork carriage class/type A, B			2A	2A
4.24	Fork carriage width	b ₃	mm	1040	1040
4.31	Ground clearance, laden, below mast	m ₁	mm	110	110
4.32	The minimum ground clearance of frame	m ₂	mm	105	105
4.34.1	Aisle width for pallets 1000 x 1200 crossways	Ast	mm	3685	3685
4.34.2	Aisle width for pallets 800 x 1200 lengthways	Ast	mm	3885	3885
4.35	Turning radius	Wa	mm	2080	2080
Performance data					
5.1	Travel speed, laden/ unladen		km/ h	10.5/14	10.5/14
5.2	Lifting speed, laden/ unladen		m/ s	0.28/ 0.42	0.28/ 0.42
5.3	Lowering speed, laden/ unladen		m/ s	0.42/ 0.45	0.43/ 0.45
5.5	Drawbar pull, laden/unladen		N	—	—
5.6	Max. drawbar pull, laden/unladen (time)		N	—	10000
5.7	Gradeability, laden/unladen		%	—	—
5.8	Max. gradeability, laden/unladen		%	10.5/14	10.5/14
5.10	Service brake type			Electromagnetic	Electromagnetic
	park brake type			Electromagnetic	Electromagnetic
Electric-engine					
6.1	Drive motor rating S2 60 min		kW	6	6
6.2	Lift motor rating at S3 15%		kW	7.5	7.5
6.3	The maximum allowed size battery		mm	956X296X640	956X296X640
6.4	Battery voltage/nominal capacity K5		V/AH	48V360AH	48V360AH
6.5	Battery weight		kg	260	260
Addition data					
8.1	Type of drive unit			AC	AC
10.5	Steering type			—	—
10.7	Sound pressure level at the driver's ear		dB (A)	—	—

If there are improvements of technical parameters or configurations, no further notice will be given.
The diagram shown may contain non-standard configurations.

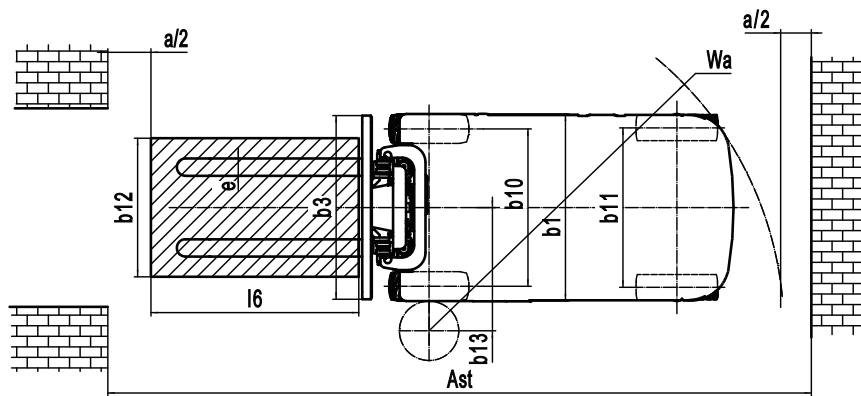
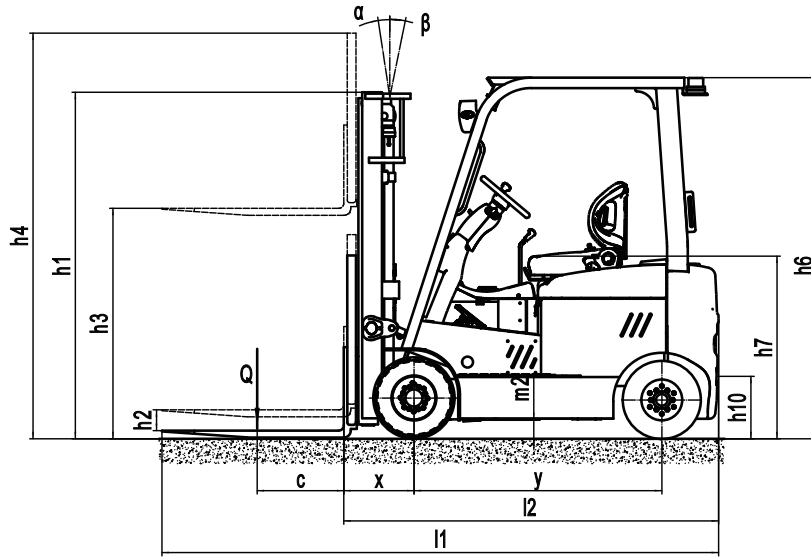

Mast Option

Type	Model	Max. fork height h3	Overall height			Free lift		Front Overhang X	Tilt range		Capacity	
			Lowered h1	Extended		Without backrest	With backrest h2		FWD α	BWD β	Load capacity at 500 mm	
				Without backrest	With backrest h4						Single tire	
											1.5t	2t
mm	mm	mm	mm	mm	mm	Deg	Deg	kg	kg			
Duplex ZT	2W200	2000	1490	2485	3028	105	105	405	6	11	1500	2000
	2W250	2500	1740	2985	3528	105	105	405	6	11	1500	2000
	2W270	2700	1840	3185	3728	105	105	405	6	11	1500	2000
	2W300	3000	1990	3485	4028	105	105	405	6	11	1500	2000
	2W330	3300	2140	3785	4328	105	105	405	6	11	1500	1960
	2W350	3500	2240	3985	4528	105	105	405	6	11	1500	1920
	2W360	3600	2290	4085	4628	105	105	405	6	11	1500	1900
2W400	4000	2540	4485	5028	105	105	405	6	11	1400	1850	
Duplex ZZ	2F250	2500	1773	2985	3528	1288	745	405	6	11	1500	2000
	2F270	2700	1873	3185	3728	1388	845	405	6	11	1500	2000
	2F300	3000	2023	3485	4028	1538	995	405	6	11	1500	2000
	2F330	3300	2173	3785	4328	1688	1145	405	6	11	1500	1960
	2F360	3600	2323	4085	4628	1838	1295	405	6	11	1500	1900
	2F400	4000	2523	4485	5028	2038	1495	405	6	11	1400	1850
Triplex DZ	3F435	4350	1995	4844	5378	1501	967	415	6	6	1300	1650
	3F450	4500	2045	4994	5528	1551	1017	415	6	6	1250	1550
	3F480	4800	2145	5294	5828	1651	1117	415	6	6	1100	1400
	3F500	5000	2210	5494	6028	1716	1182	415	3	6	950	1250

RATED CAPACITIES AND LOAD CENTERES GRAPH

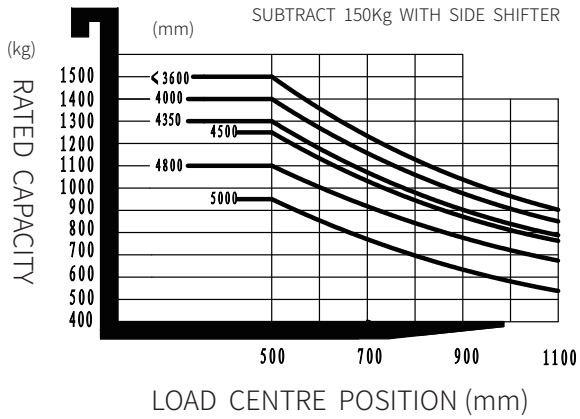

RATED CAPACITIES AND LOAD CENTERES GRAPH

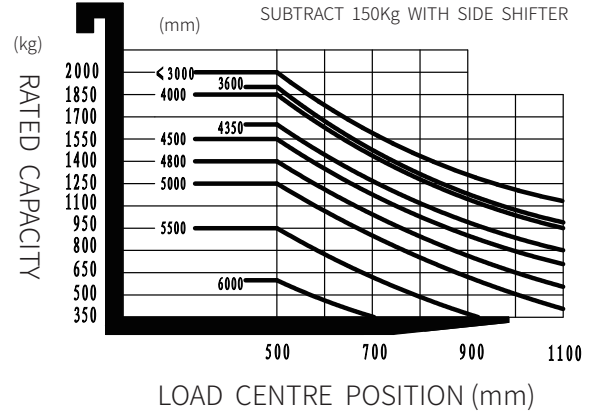

Option

Optional items		CPD15L1/20L1
3	Fork length	○
6	Folding fork	○
7	Weighting system with fork	○
12	Solid rubber tire	●
13	Environmental solid tire	○
15	cold storage	—
19	Battery capacity	○
20	Lateral change battery	●
21	Import battery	—
22	Water auto-filling system	—
30	Side shift	○
37	Overhead guard	○
39	Mast options	○
40	Attachments	○
41	Proportional valve	—
42	Front light	●
43	Back light	○
46	Warning light	●
48	Fire extinguisher	○
49	Seat	○
50	Seat switch	○
51	With fan heater	—
52	With front windshield wiper	—
53	With rear windshield wiper	—
54	Cockpit	—
55	Doulbe front wheel	—
56	Rearview	●
57	OPS system	○
58	Backrest width	○
59	Side to pull the car	○
60	Air fan	○
61	Charging voltage	○
62	Drive-in Rack	○

Note: ● standard ○ option — NA

Electric Counterbalance Forklift Truck 3.0/3.5T CPD30/35L1B

Distinguishing mark					
1.1	Manufacturer			EP	EP
1.2	Model designation			CPD30L1B	CPD35L1B
1.3	Drive unit			Electrics	Electrics
1.4	Operator type			Seated	Seated
1.5	rated capacity	Q	t	3	3.5
1.6	Load center distance	c	mm	500	500
1.8	Load distance, centre of drive axle to fork	x	mm	500	500
1.9	Wheelbase	y	mm	1698	1698
Weight					
2.1	Service weight (include battery)		kg	4530	4675
2.2	Axle loading, laden driving wheels /steering wheels		kg	6760/770	7565/610
2.3	Axle loading, unladen driving wheels /steering wheels		kg	1990/2540	2005/2670
Types,Chassis					
3.1	Tyre type,driving wheels /steering wheels			Solid Rubber	Solid Rubber
3.2	Tyre size, driving wheels (diameterxwidth)		mm	23X9-10(577X212)	23X10-12(578X228)
3.3	Tyre size, steering wheels (diameterxwidth)		mm	200/50-10(453X194)	200/50-10(453X194)
3.5	Wheels, number driving/steering (x=drive wheels)		mm	2x/ 2	2x/ 2
3.6	Tread, Driving wheels	b10	mm	1085	1100
3.7	Tread, Steering wheels	b11	mm	1020	1020
Dimensions					
4.1	Tilt of mast/fork carriage forward/backward	α / β (°)		5 / 9	5/ 9
4.2	Height, mast lowered	h1	mm	2210	2210
4.3	Free lift (load backrest)	h2	mm	140	140
4.4	Lift height	h3	mm	3000	3000
4.5	Height, mast extended	h4	mm	4095	4095
4.7	Height of overhead guard (cabin)	h6	mm	2210	2210
4.8	Seat height	h7	mm	1120	1120
4.12	Tow center of pin height	h10	mm	380	380
4.19	Overall length	l1	mm	3640	3640
4.20	Length to face of forks	l2	mm	2570	2570
4.21	Overall width	b1/ b2	mm	1298	1356
4.22	Fork dimensions	s/ e/ l	mm	45x125x1070	50x125x1070
4.23	Fork carriage class/type A, B			3A	3A
4.24	Fork carriage width	b3	mm	1228	1228
4.31	Ground clearance, laden, below mast	m1	mm	130	130
4.32	The minimum ground clearance of frame	m2	mm	125	125
4.34.1	Aisle width for pallets 1000 x 1200 crossways	Ast	mm	4090	4090
4.34.2	Aisle width for pallets 800 x 1200 lengthways	Ast	mm	4290	4290
4.35	Turning radius	Wa	mm	2390	2390
Performance data					
5.1	Travel speed, laden/ unladen		km/ h	11/13	11/13
5.2	Lifting speed, laden/ unladen		m/ s	0.25/0.37	0.25/0.37
5.3	Lowering speed, laden/ unladen		m/ s	0.44/ 0.48	0.44/ 0.48
5.5	Drawbar pull, laden/unladen		N	—	—
5.6	Max. drawbar pull, laden/unladen (time)		N	—	—
5.7	Gradeability, laden/unladen		%	—	—
5.8	Max. gradeability, laden/unladen		%	12/15	12/15
5.9	Service brake type			Mechanics + Hydraulic	Mechanics + Hydraulic
5.10	park brake type			Mechanics	Mechanics
Electric-engine					
6.1	Drive motor rating S2 60 min		kW	12	12
6.2	Lift motor rating at S3 15%		kW	10	10
6.3	The maximum allowed size battery		mm	891X550X680	891X550X680
6.4	Battery voltage/nominal capacity K5		V/ Ah	80V270AH	80V270AH
6.5	Battery weight		kg	290	290
Addition data					
8.1	Type of drive unit			AC	AC
10.5	Steering type			—	—
10.7	Sound pressure level at the driver's ear		dB (A)	70	70

If there are improvements of technical parameters or configurations, no further notice will be given.
The diagram shown may contain non-standard configurations.

Electric Counterbalance Forklift Truck 3.0/3.5T CPD30/35L1S

Distinguishing mark					
1.1	Manufacturer			EP	EP
1.2	Model designation			CPD30L1S	CPD35L1S
1.3	Drive unit			Electrics	Electrics
1.4	Operator type			Seated	Seated
1.5	rated capacity	Q	t	3	3.5
1.6	Load center distance	c	mm	500	500
1.8	Load distance, centre of drive axle to fork	x	mm	500	500
1.9	Wheelbase	y	mm	1698	1698
Weight					
2.1	Service weight (include battery)		kg	4830	5360
2.2	Axle loading, laden driving wheels /steering wheels		kg	6840/990	7750/1110
2.3	Axle loading, unladen driving wheels /steering wheels		kg	2065/2765	2185/3175
Types,Chassis					
3.1	Tyre type,driving wheels /steering wheels			Solid Rubber	Solid Rubber
3.2	Tyre size, driving wheels (diameterxwidth)		mm	23X10-12 (578X228)	23X10-12 (578X228)
3.3	Tyre size, steering wheels (diameterxwidth)		mm	200/50-10 (453X194)	200/50-10 (453X194)
3.5	Wheels, number driving/steering (x=drive wheels)		mm	2x/ 2	2x/ 2
3.6	Tread, Driving wheels	b10	mm	1100	1100
3.7	Tread, Steering wheels	b11	mm	1020	1020
Dimensions					
4.1	Tilt of mast/fork carriage forward/backward	α/ β (°)		5/ 9	5/ 9
4.2	Height, mast lowered	h1	mm	2210	2210
4.3	Free lift (load backrest)	h2	mm	140	140
4.4	Lift height	h3	mm	3000	3000
4.5	Height, mast extended	h4	mm	4095	4095
4.7	Height of overhead guard (cabin)	h6	mm	2210	2210
4.8	Seat height	h7	mm	1120	1120
4.12	Tow center of pin height	h10	mm	380	380
4.19	Overall length	l1	mm	3640	3660
4.20	Length to face of forks	l2	mm	2570	2590
4.21	Overall width	b1/ b2	mm	1356	1356
4.22	Fork dimensions	s/ e/ l	mm	45x125x1070	50x125x1070
4.23	Fork carriage class/type A, B			3A	3A
4.24	Fork carriage width	b3	mm	1228	1228
4.31	Ground clearance, laden, below mast	m1	mm	130	130
4.32	The minimum ground clearance of frame	m2	mm	125	125
4.34.1	Aisle width for pallets 1000 x 1200 crossways	Ast	mm	4090	4100
4.34.2	Aisle width for pallets 800 x 1200 lengthways	Ast	mm	4290	4300
4.35	Turning radius	Wa	mm	2390	2400
Performance data					
5.1	Travel speed, laden/ unladen		km/ h	15/16	15/16
5.2	Lifting speed, laden/ unladen		m/ s	0.4/0.45	0.4/0.45
5.3	Lowering speed, laden/ unladen		m/ s	0.44/ 0.48	0.44/ 0.48
5.5	Drawbar pull, laden/unladen		N	—	—
5.6	Max. drawbar pull, laden/unladen (time)		N	—	17800
5.7	Gradeability, laden/unladen		%	—	—
5.8	Max. gradeability, laden/unladen		%	16/20	16/20
5.9	Service brake type			Mechanics + Hydraulic	Mechanics+ Hydraulic
5.10	park brake type			Mechanics	Mechanics
Electric-engine					
6.1	Drive motor rating S2 60 min		kW	16.6	16.6
6.2	Lift motor rating at S3 15%		kW	24	24
6.3	The maximum allowed size battery		mm	891X550X680	891X550X680
6.4	Battery voltage/nominal capacity K5		V/ Ah	80V540AH	80V540AH
6.5	Battery weight		kg	420	420
Addition data					
8.1	Type of drive unit			AC	AC
10.5	Steering type			—	—
10.7	Sound pressure level at the driver's ear		dB (A)	70	70

If there are improvements of technical parameters or configurations, no further notice will be given.
The diagram shown may contain non-standard configurations.

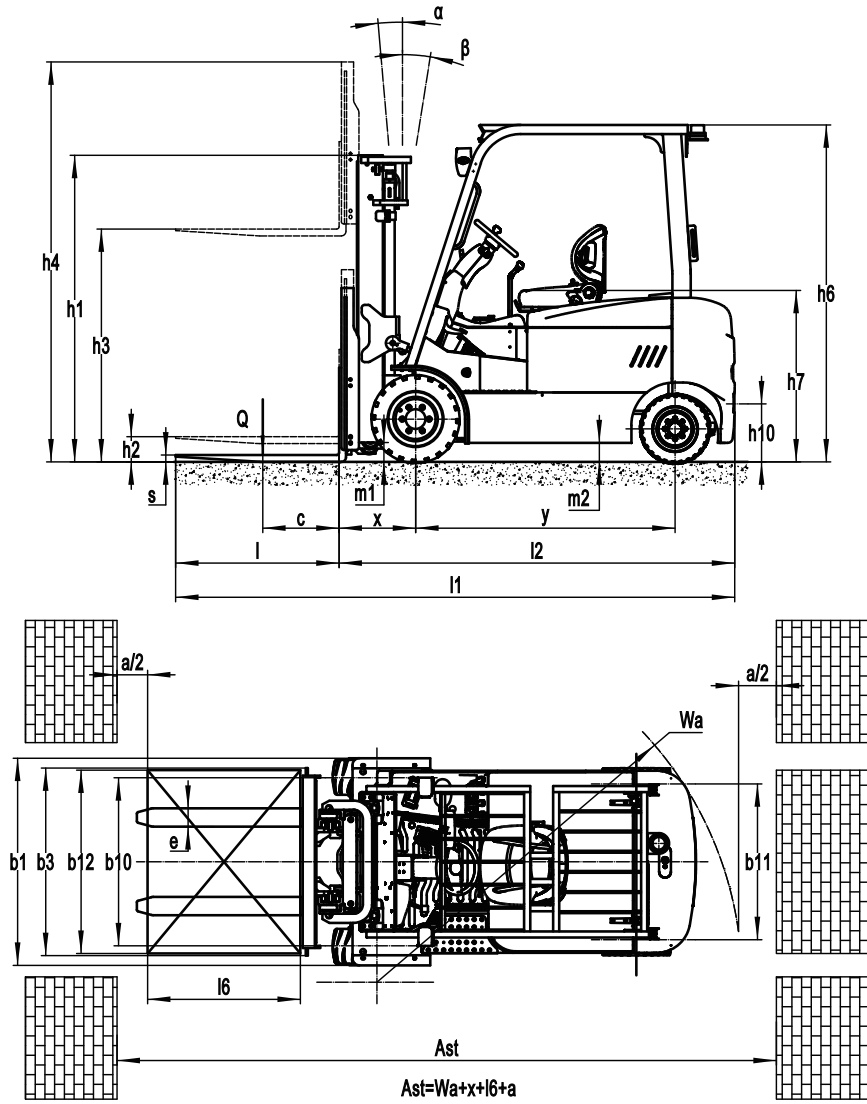

Mast Option

Type	Model	Max. fork height h3	Overall height				Free lift				Tilt range		Capacity	
			Lowered h1	Extended		Without backrest	With backrest h2	Front Overhang X		FWD α	BWD β	Load capacity at 500 mm		
				Without backrest	With backrest h4			3t	3.5t			Single tire		
												3t	3.5t	
mm	mm	mm	mm	mm	mm	mm	mm	Deg	Deg	kg	kg			
Duplex ZT	2W200	2000	1560	2705	3095	140	140	500	500	5	9	3000	3500	
	2W250	2500	1810	3205	3595	140	140	500	500	5	9	3000	3500	
	2W270	2700	1910	3405	3795	140	140	500	500	5	9	3000	3500	
	2W300	3000	2060	3705	4095	140	140	500	500	5	9	3000	3500	
	2W330	3300	2210	4005	4395	140	140	500	500	5	9	3000	3500	
	2W350	3500	2310	4205	4595	140	140	500	500	5	9	3000	3500	
	2W360	3600	2360	4305	4695	140	140	500	500	5	9	3000	3500	
	2W400	4000	2610	4705	5095	140	140	500	500	5	9	2850	3250	
	2W430	4300	2760	5005	5395	140	140	500	500	5	6	2700	3000	
2W450	4500	2860	5205	5595	140	140	500	500	5	6	2550	2850		
Duplex ZZ	2F250	2500	1790	3215	3595	1075	695	500	500	5	9	3000	3500	
	2F270	2700	1890	3415	3795	1175	795	500	500	5	9	3000	3500	
	2F300	3000	2040	3715	4095	1325	945	500	500	5	9	3000	3500	
	2F330	3300	2190	4015	4395	1475	1095	500	500	5	9	3000	3500	
	2F360	3600	2340	4315	4695	1625	1245	500	500	5	9	3000	3000	
	2F400	4000	2440	4715	5095	1725	1345	500	500	5	9	2850	3000	
Triplex DZ	3F430	4300	2040	5005	5395	1335	945	515	515	5	6	2550	3250	
	3F450	4500	2120	5205	5595	1415	1025	515	515	5	6	2400	2850	
	3F480	4800	2225	5505	5895	1520	1130	515	515	5	6	2250	2500	
	3F500	5000	2310	5705	6095	1605	1215	515	515	5	6	2100	2300	
	3F550	5500	2560	6205	6595	1855	1465	515	515	3	6	1650	1750	
	3F600	6000	2810	6705	7095	2105	1715	515	515	3	6	1200	1250	

RATED CAPACITIES AND LOAD CENTERES GRAPH

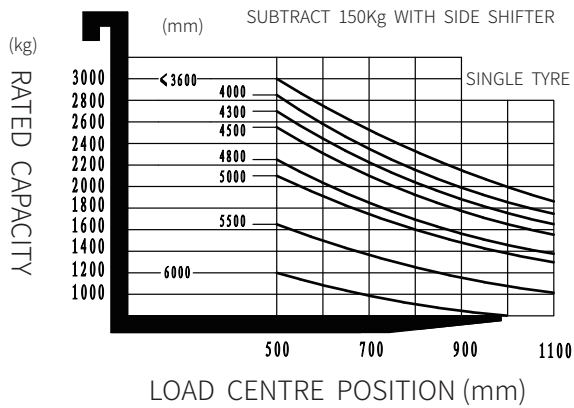

RATED CAPACITIES AND LOAD CENTERES GRAPH

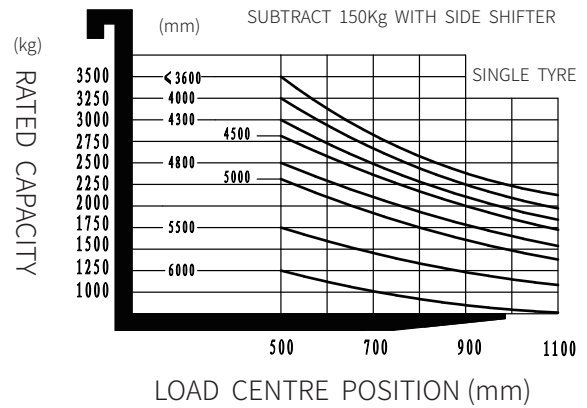

Option

Optional items		CPD30/35L1
3	Fork length	○
6	Folding fork	○
7	Weighting system with fork	○
12	Solid rubber tire	●
13	Environmental solid tire	○
15	cold storage	—
19	Battery capacity	○
20	Lateral change battery	—
21	Import battery	—
22	Water auto-filling system	—
30	Side shift	○
37	Overhead guard	○
39	Mast options	○
40	Attachments	○
41	Proportional valve	—
42	Front light	●
43	Back light	○
46	Warning light	●
48	Fire extinguisher	○
49	Seat	○
50	Seat switch	○
51	With fan heater	○
52	With front windshield wiper	○
53	With rear windshield wiper	○
54	Cockpit	○
55	Doulbe front wheel	—
56	Rearview	●
57	OPS system	○
58	Backrest width	○
59	Side to pull the car	—
60	Air fan	○
61	Charging voltage	○
62	Drive-in Rack	○

Note: ● standard ○ option — NA